

Wearable Temperature Sensing Layout Considerations Optimized for Thermal Response

Emmy Denton

ABSTRACT

This application note covers thermal response considerations for sensors that come in a DSBGA package for measuring skin temperature for applications such as wearables such as fitness bands and medical devices. It will specifically focus on the LMT70, a 0.88mm x 0.88m 0.13°C max accuracy (0.05°C typ) temp sensor over the human body temperature range, but learning can be applied to other temperature sensors that come in a similar package, whether they be analog or digital sensors. Contact temperature sensors, such as the LMT70, need to be placed in close contact with the surface that needs to be measured. This can be quite challenging for the DSBGA package that is if fast thermal response is also necessary. Experimental results of different PCB layouts will be presented when measuring axillary.

Contents

1	Introduction	1
2	Small LMT70 Probe Board Description	3
3	The Measurement System.....	4
4	Probe Board Test Results	4
5	Appendix	5
6	References	6

List of Figures

1	LMT70 Block Diagram	2
2	LMT70 PCB path of heat flow (thermal conductivity of materials, k in W/mK, given in parenthesis)	3
3	Close up of LMT70 mounted on a PCB with underfill material	3
4	Small LMT70 Probe Board Top Side.....	3
5	Small LMT70 Probe Board Bottom Side.....	3
6	LMT70 Probe Board Thermal Response Measurement System	4
7	Comparison of the Small PCB to other types of substrates when measuring axillary body temperature.	5
8	Thin PCB.....	5
9	Flex PCB.....	5
10	Regular PCB (from LMT70 Evaluation Module)	6

1 Introduction

The two major concerns for measuring body temperature in wearables are accuracy and speed. The LMT70 is a 4-pin analog temperature sensor that comes in a DSBGA package that is 0.88 mm x 0.88 mm. Its small size means small thermal mass thus quick response. The LMT70 also includes internal calibration making it one of the most accurate analog IC temperature sensors in the market. The LMT70's typical accuracy of 0.05°C from 25°C to 45°C makes it ideal for measuring body temperature. This application note will discuss the PCB layout considerations required to achieve good thermal conductivity as well as fast thermal response for the LMT70 as PCB layout can dramatically affect these parameters.

The LMT70 temperature sensing circuitry is based on the transistor base emitter diode junction thermal properties. The diode voltage is then amplified and buffered as shown in Figure 1. The sensing element of the LMT70 consists of stacked BJT base emitter junctions that are biased by a current source. The output of the sensing element is buffered by a precision amplifier whose class AB push-pull output stage can easily source and sink currents of up to 3 mA. The amplifier output connects to an output switch that is turned on and off by the digital control input T_ON (see Figure 1). This switch allows for the multiplexing of multiple sensors on one signal line.

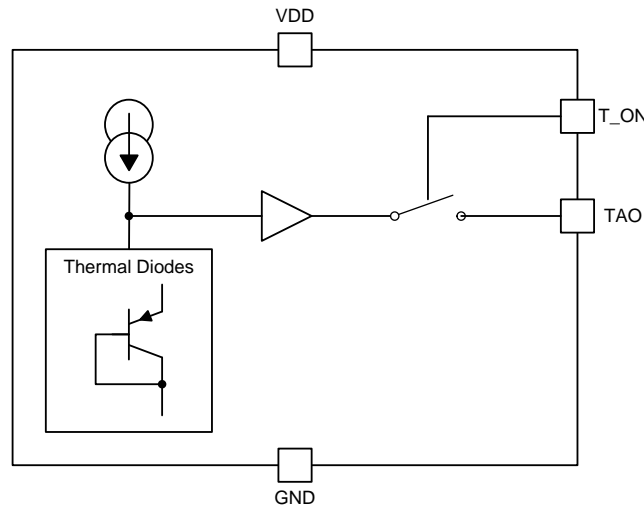

Figure 1. LMT70 Block Diagram

The LMT70 is a contact sensor, thus making good contact with the surface that is measured is of primary importance. There are several methods of heat transfer conduction, convection and radiation. For the LMT70 the main method is conduction. Thermal conductivity is the main parameter of a material that needs to be considered in addition to the contact area and the length material. Thermal conductivity (W/(mK)) of several materials that may be used in the production of a PCB are given in the table shown in Table 1.

Table 1. Thermal Conductivity of Different Materials

Material	Thermal Conductivity (k in W/mK)
Air	0.023 to 0.045
Wood	0.04 to 0.3
Epoxy coating on top of LMT70 die	0.2 to 0.3
FR4	0.4
Polyimide	0.5
Thermally Conductive Epoxy	1 to 7
LMT70 Solder Ball	7 to 8
Stainless Steel	16 to 24
Solder (63/67)	39
Nickle	91
Silicon	100 to 120
Aluminum	204 to 250
Gold	320
Copper	400
Silver	425
Diamond	900<

The higher the k factor the better the thermal conductivity thus the faster the response time. Maintaining a small thermal mass will improve the thermal response time of the circuit. This is where good thermal modeling software becomes a necessity. Shown in Figure 4 is a cross section of an LMT70 mounted on a PCB. As can be seen in the Thermal Conductivity of Different Thermal Materials table copper is a very good thermal conductor and so is solder. The red arrow shows the heat flow path from the back side of the PCB to the LMT70 active circuitry (cross hatched area) through metal portions of the PCB (the traces, pads, and solder balls). Since there is air surrounding the part and the solder balls in this example the thermal conductivity is compromised. Better results can be obtained if underfill is added surrounding the LMT70 die (package) as shown in Figure 3, thus improving the conductivity to the actual silicon which has very high thermal conductivity. FR4 and Polyimide insulators do not have very good thermal conductivity thus their thickness should be minimized.

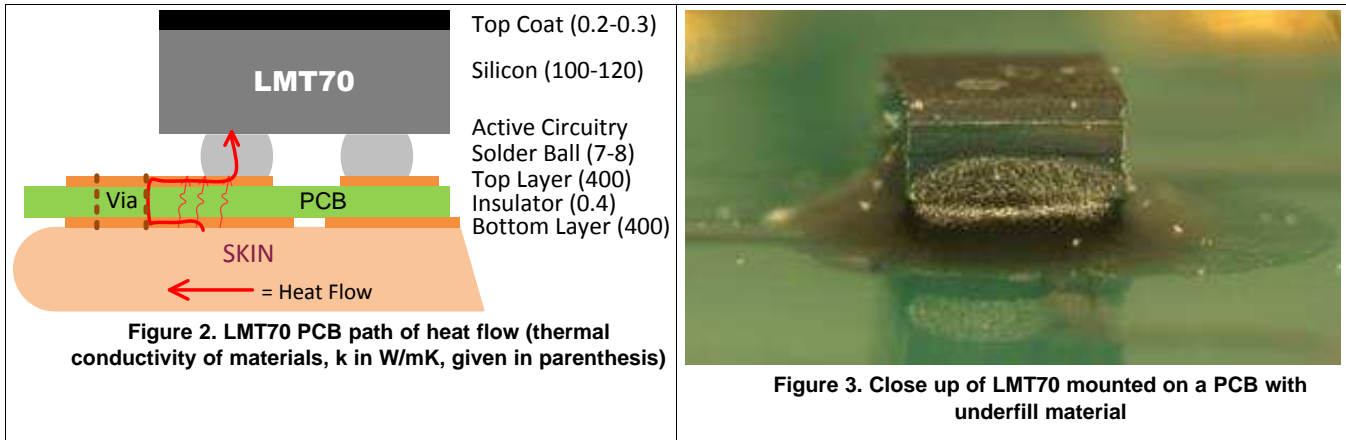

2 Small LMT70 Probe Board Description

As mentioned previously size matters and so does the material you use. The following board was designed to optimize the thermal response time of the LMT70. The board was made very small approaching minimum sizes for PCB manufacturing. The back side of the board has large surface area with vias to the top side as shown in Figure 4 and Figure 5.

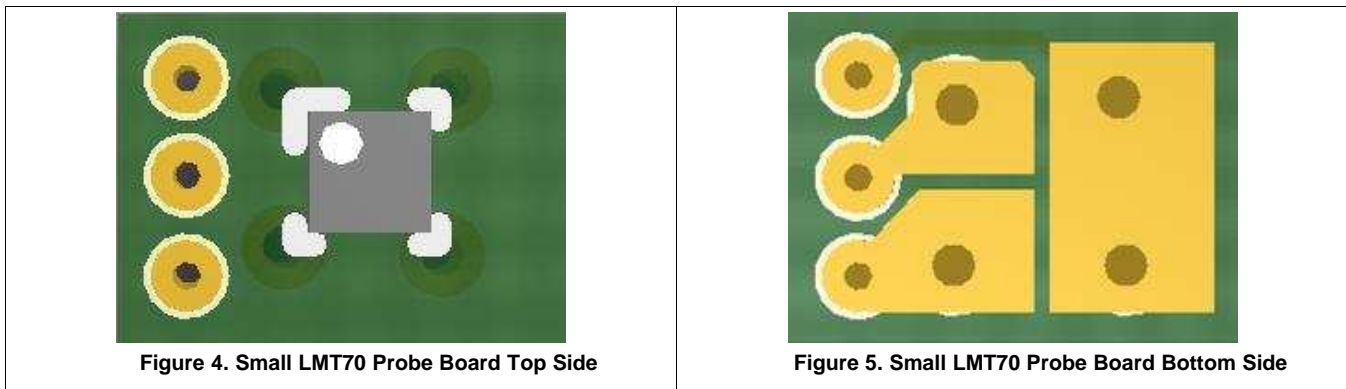

Probe Board Dimensions

- Width: 115mil (2.9mm)
- Height: 85mil (2.16mm)
- Thickness: 20mil with 1oz copper
- Via size: 12mil hole, 24mil diameter
- Wire pad: 8mil hole, 20mil diameter
- No bottom side solder mask

Boards are all assembled with LMT70 first with the panel intact. Then the LMT70s were epoxied to the board. Forty gauge nickel wire was soldered to the PCB connecting holes for connection purposes as shown in Figure 6. Nickel was chosen for the wire material as it has lower thermal conductivity than copper. The small diameter wire was chosen because of its small mass. This type of wire was used in order to minimize the thermal effects of the wires to the PCB response time. The wires attached to the PCB can act as a heat sink thus lower thermal mass and lower thermal conductivity would minimize the heat sink affect. Holes were used rather than pads in order to provide more mechanical strength to the wire assembly. Four mil copper traces and 40 AWG copper wire should affect the response time by a very small amount as the main benefits of this layout are the exposed copper bottom side pads and vias.

We are working on identifying thermally conductive but electrically isolating under-fill material (such as Henkel 3800 or 3810) that will work in helping with the thermal conductivity on the top side (see Figure 3). It will enable an automated production environment as the epoxy glue that was used for this experiment was hand applied. Comparison results will be published in a revision of this app note.

3 The Measurement System

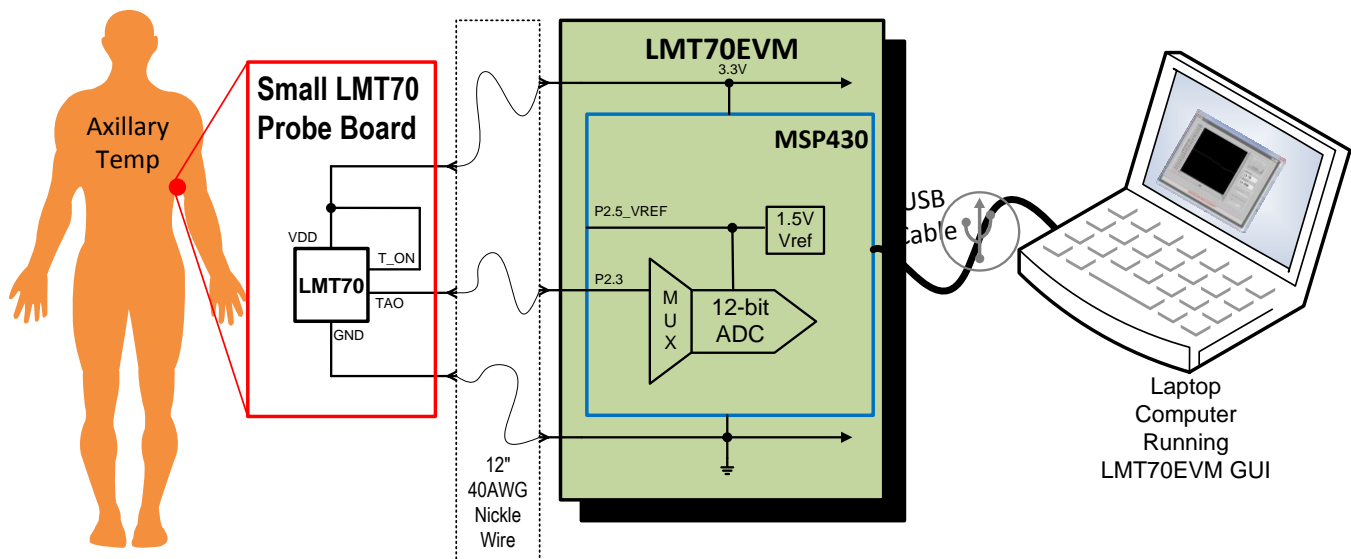

Figure 6. LMT70 Probe Board Thermal Response Measurement System

The LMT70 Probe board was connected to the LMT70EVM through 40AWG wires as shown in Figure 6. The LMT70 output temperature was recorded using the LMT70EVM GUI. The LMT70EVM is USB powered. See TI Design “Temperature Sensor for Wearable Devices Reference Design” ([TDA-00452](#)) and the LMT70EVM for more information on the GUI and firmware source code and performance of the system.

4 Probe Board Test Results

The curve in Figure 7 shows the percent of final value on the Y axis and time in seconds on the X axis. Initial temperature of about 22C is the initial 0% level as shown in the curve. The 100% level of course is the axillary skin temperature. It is common to normalize and the thermal response time of a temperature sensor in this manner. Usually thermal time constant is given to the 63% level, similar to RC time constant. This is a good way to compare the response time of different boards as it normalizes the starting temperature of the test and allows easy comparison. As can be seen in Figure 8, the **Small LMT70 Probe Board** (purple trace) improves upon the thermal response time performance when compared to several other types of PCBs by about 100 seconds to the 99% (black trace) of final value. The next best performing PCB is the flex PCB shown in green. More information on the **Thin PCB** (red), **Flex PCB** (green), and **Regular PCB** (blue) can be found in the TI Design “Temperature Sensor for Wearable Devices Reference Design” ([TIDA-00452](#)) and Section 5.

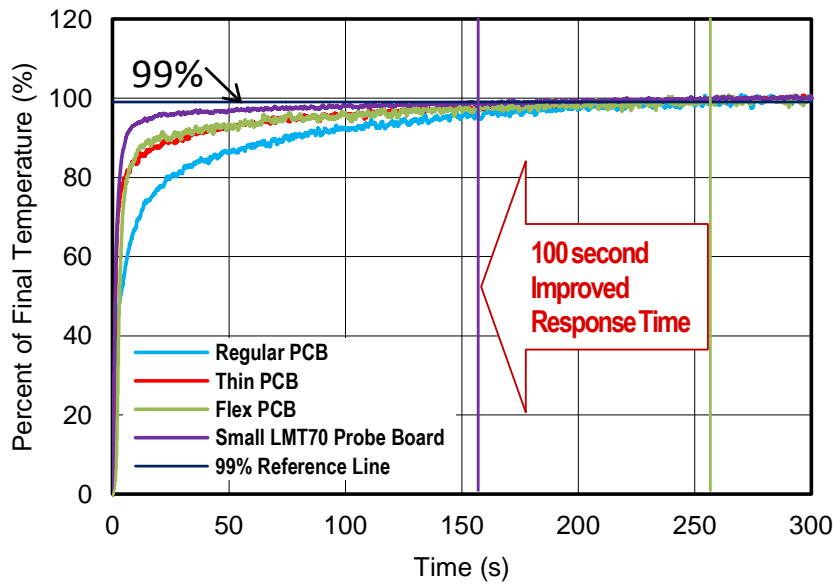

Figure 7. Comparison of the Small PCB to other types of substrates when measuring axillary body temperature.

5 Appendix

5.1 Other Board Descriptions

For quick review the additional LMT70 boards are described in this section briefly. These boards have a color coded boarder to match the traces as shown in Figure 7 for easy reference purposes. The red trace thin PCB is 2mm wide at the right, (8mm wide at left), and 0.5mm thick with 0.102mm (4 mil) traces. The LMT70 mounts at the far right. No thermal vias or pads are on the back side of the board.



Figure 8. Thin PCB

The green trace Flex PCB has the LMT70 mounted in the middle. It has a stiffener on the back side of the LMT70 in order to provide mechanical stability to the LMT70 mounting.



Figure 9. Flex PCB

The blue trace Regular PCB is the LMT70EVM which is standard 12 mil thickness but has very small 4 mil traces. The LMT70 is mounted on the far right. The size of the PCB is 850 mils or 21mm by 600 mils or 15mm with thickness of 1.5mm.

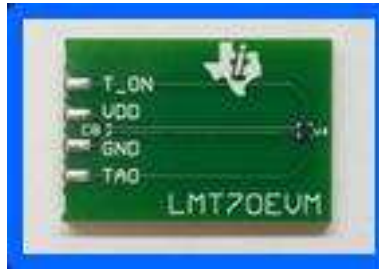

Figure 10. Regular PCB (from LMT70 Evaluation Module)

6 References

- *LMT70, LMT70A $\pm 0.1^{\circ}\text{C}$ Precision Analog Temperature Sensor, RTD and Precision NTC Thermistor IC Data Sheet* ([LMT70 Datasheet](#).)
- *LMT70 Evaluation Module Precise Analog Output Temperature Sensor with Output Enable* ([LMT70 EVM](#))
- *TI Design: Temperature Sensor for Wearable Devices Reference Design* ([LMT70 TI Design](#))

IMPORTANT NOTICE

Texas Instruments Incorporated and its subsidiaries (TI) reserve the right to make corrections, enhancements, improvements and other changes to its semiconductor products and services per JESD46, latest issue, and to discontinue any product or service per JESD48, latest issue. Buyers should obtain the latest relevant information before placing orders and should verify that such information is current and complete. All semiconductor products (also referred to herein as "components") are sold subject to TI's terms and conditions of sale supplied at the time of order acknowledgment.

TI warrants performance of its components to the specifications applicable at the time of sale, in accordance with the warranty in TI's terms and conditions of sale of semiconductor products. Testing and other quality control techniques are used to the extent TI deems necessary to support this warranty. Except where mandated by applicable law, testing of all parameters of each component is not necessarily performed.

TI assumes no liability for applications assistance or the design of Buyers' products. Buyers are responsible for their products and applications using TI components. To minimize the risks associated with Buyers' products and applications, Buyers should provide adequate design and operating safeguards.

TI does not warrant or represent that any license, either express or implied, is granted under any patent right, copyright, mask work right, or other intellectual property right relating to any combination, machine, or process in which TI components or services are used. Information published by TI regarding third-party products or services does not constitute a license to use such products or services or a warranty or endorsement thereof. Use of such information may require a license from a third party under the patents or other intellectual property of the third party, or a license from TI under the patents or other intellectual property of TI.

Reproduction of significant portions of TI information in TI data books or data sheets is permissible only if reproduction is without alteration and is accompanied by all associated warranties, conditions, limitations, and notices. TI is not responsible or liable for such altered documentation. Information of third parties may be subject to additional restrictions.

Resale of TI components or services with statements different from or beyond the parameters stated by TI for that component or service voids all express and any implied warranties for the associated TI component or service and is an unfair and deceptive business practice. TI is not responsible or liable for any such statements.

Buyer acknowledges and agrees that it is solely responsible for compliance with all legal, regulatory and safety-related requirements concerning its products, and any use of TI components in its applications, notwithstanding any applications-related information or support that may be provided by TI. Buyer represents and agrees that it has all the necessary expertise to create and implement safeguards which anticipate dangerous consequences of failures, monitor failures and their consequences, lessen the likelihood of failures that might cause harm and take appropriate remedial actions. Buyer will fully indemnify TI and its representatives against any damages arising out of the use of any TI components in safety-critical applications.

In some cases, TI components may be promoted specifically to facilitate safety-related applications. With such components, TI's goal is to help enable customers to design and create their own end-product solutions that meet applicable functional safety standards and requirements. Nonetheless, such components are subject to these terms.

No TI components are authorized for use in FDA Class III (or similar life-critical medical equipment) unless authorized officers of the parties have executed a special agreement specifically governing such use.

Only those TI components which TI has specifically designated as military grade or "enhanced plastic" are designed and intended for use in military/aerospace applications or environments. Buyer acknowledges and agrees that any military or aerospace use of TI components which have **not** been so designated is solely at the Buyer's risk, and that Buyer is solely responsible for compliance with all legal and regulatory requirements in connection with such use.

TI has specifically designated certain components as meeting ISO/TS16949 requirements, mainly for automotive use. In any case of use of non-designated products, TI will not be responsible for any failure to meet ISO/TS16949.

Products

Audio	www.ti.com/audio
Amplifiers	amplifier.ti.com
Data Converters	dataconverter.ti.com
DLP® Products	www.dlp.com
DSP	dsp.ti.com
Clocks and Timers	www.ti.com/clocks
Interface	interface.ti.com
Logic	logic.ti.com
Power Mgmt	power.ti.com
Microcontrollers	microcontroller.ti.com
RFID	www.ti-rfid.com
OMAP Applications Processors	www.ti.com/omap
Wireless Connectivity	www.ti.com/wirelessconnectivity

Applications

Automotive and Transportation	www.ti.com/automotive
Communications and Telecom	www.ti.com/communications
Computers and Peripherals	www.ti.com/computers
Consumer Electronics	www.ti.com/consumer-apps
Energy and Lighting	www.ti.com/energy
Industrial	www.ti.com/industrial
Medical	www.ti.com/medical
Security	www.ti.com/security
Space, Avionics and Defense	www.ti.com/space-avionics-defense
Video and Imaging	www.ti.com/video

TI E2E Community

e2e.ti.com